

ECE 3042

Homework Assignment No. 3

Spring 2013 Homework for Experiment No. 3

Due Week of February 4

1. Design an inverting bandpass op amp amplifier/filter with a midband voltage gain with a magnitude of 7.3, a lower -3dB frequency of 73 Hz , and an upper -3dB frequency of 73 kHz . The circuit shown in Fig. 1 is suggested. Pick the capacitor $C_1 = 0.1\ \mu\text{F}$ and compute the other components. Perform an ac analysis with National Instruments SPICE to plot the magnitude of the voltage gain as a function of frequency as the frequency ranges from 1 Hz to 1 MHz . Assume that the op amp is ideal. Plot the magnitude and phase of the frequency response with Mathcad.

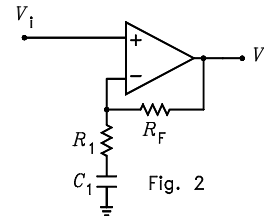
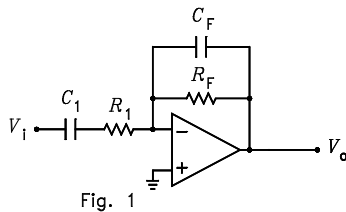

2. Design an op amp noninverting high pass shelving amplifier/filter. The dc gain is to be 1, the infinite frequency gain 7.3, and the pole frequency 7.3 kHz . The circuit shown in Fig. 2 is suggested. Pick $C_1 = 0.1\ \mu\text{F}$ and solve for the other circuit components. Perform an ac analysis with National Instruments SPICE to plot the magnitude of the voltage gain as a function of frequency as the frequency ranges from 1 Hz to 1 MHz . Assume that the op amp is ideal. Plot the magnitude and phase of the frequency response with Mathcad.

3. Design an opamp noninverting amplifier/filter that uses a single dc power supply. The input is to be capacitively coupled to prevent dc voltage from appearing on the source. The circuit is to have a high pass characteristic with a high frequency gain of 7.3 and a pole frequency of 7.3 kHz . The circuit shown in Fig. 3 is suggested. Pick $C_1 = C_2 = 0.1\ \mu\text{F}$ and compute the other circuit components. Perform an ac analysis with National Instruments SPICE to plot the magnitude of the voltage gain as a function of frequency as the frequency ranges from 1 Hz to 1 MHz . Assume that the op amp is ideal. Plot the magnitude and phase of the frequency response with Mathcad.

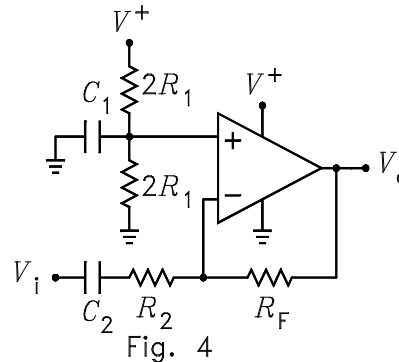
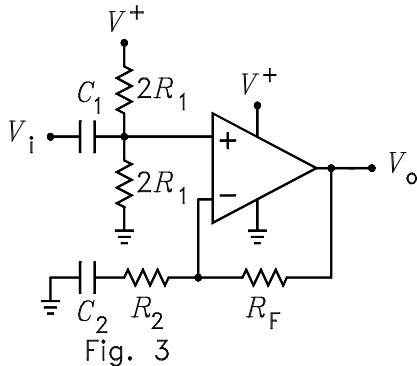

4. Design an opamp inverting amplifier/filter that uses a single dc power supply. The input is to be capacitively coupled to prevent dc voltage from appearing on the source. The circuit is to have a high pass characteristic with a high frequency gain with a magnitude of 7.3 and a pole frequency of 7.3 kHz . The circuit shown in Fig. 4 is suggested. Pick $C_1 = C_2 = 0.1\ \mu\text{F}$ and compute the other circuit components. Perform an ac analysis with National Instruments SPICE to plot the magnitude of the voltage gain as a function of frequency as the frequency ranges from 1 Hz to 1 MHz . Assume that the op amp is ideal. The value of R_1 is irrelevant. Plot the magnitude and phase of the frequency response with Mathcad.